

 **CORGI**

A224 - A224A

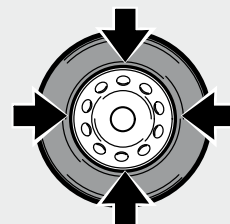

24''



14''



Versione con discesa automatica del braccio
Version with automatic lowering of the head arm
Ausführung mit automatischer Verstellung des Montagekopfes

Smontagomme automatico con palo ribaltabile pneumaticamente



Automatic tyre changer with pneumatic tilting column



Automatische Reifenmontiermaschine mit pneumatisch kippbarer Montagesäule





A richiesta: disponibile nella versione DV e con sistema di intallatura e gonfiaggio T.I..
On request: available in DV version and with T.I. inflation system and alloy spot rims.
Auf Anfrage: lieferbar in der Version DV und TI-Version zum Wulsteindrücken und Aufpumpen.

1 PALO PORTA BRACCIO / ARM SUPPORT COLUMN / KIPPBARE MONTAGESÄULE

PALO PORTA BRACCIO ribaltabile pneumaticamente ad elevata rigidità torsionale in tutte le posizioni di lavoro.

PNEUMATICALLY-OPERATED TILTING ARM SUPPORT COLUMN with high torsional rigidity, can be tilted in any working position.

PNEUMATISCH KIPPBARE MONTAGESÄULE mit erhöhter Torsionssteifigkeit in allen Arbeitspositionen



Versione A 224A - A 224A version - Versionen A 224A

2 APPOGGI SCORREVOLI SLIDING SUPPORTS VERSCHIEBBARE RADAUFLAGEN



Appoggi scorrevoli con punte di bloccaggio intercambiabili. Griffe in fusione più alte per un miglior bloccaggio del cerchio dall'interno e dall'esterno.

Sliding supports with interchangeable clamping centres. Higher cast clamps for improved rim clamping from inside and outside

Verschiebbare Radauflagen mit auswechselbaren Spitzen. Höhere Spannklaue aus Speziallegierung zum stabileren Spannen der Felge von innen und von außen

3 AUTOCENTRANTE - TURNTABLE SPANNFUTTER



Autocentrante con doppio cilindro pneumatico in grado di bloccare saldamente ogni tipo di cerchio.

Turntable with two pneumatic cylinders able to safely clamp any type of rim

Spannfutter mit zwei Druckluftzylindern, zum sicheren Aufspannen von Felgen jeder Art.

4 BRACCIO ORIZZONTALE HORIZONTAL ARM - HORIZONTALARM

Braccio orizzontale (esagonale) telescopico per un rapido posizionamento della torretta rispetto al cerchio.
Telescopic (hexagonal) horizontal arm for quicker positioning of the head in relation to the rim.
Teleskopischer Horizontalarm (sechseckig) für ein rasches Ansetzen des Montagekopfs an die Felge



5 BLOCCAGGIO PNEUMATICO/ PNEUMATIC LOCKING / PNEUMATISCHE ARRETIERUNG



Bloccaggio pneumatico **simultaneo** del braccio orizzontale e di quello verticale porta torretta con posizionamento automatico di quest'ultima nella posizione ideale di lavoro. **Automatico** (A) e **Manuale** (B).

Simultaneous pneumatic locking of the horizontal arm and head carrier vertical arm with automatic positioning of the latter to ideal working position. Automatic (A) e Manual (B).

Gleichzeitige Pneumatische arretierung von Horizontal- und Vertikalarm mit automatischer Positionierung des Montagekopfs in der optimalen Arbeitsstellung. Automatische (A) und Manuelle (B).

6 PEDALIERA ESTRAIBILE - EXTRACTABLE PEDAL CONTROL - AUSZIEHBARE PEDALEINHEIT

Pedaliera estraibile, una grande comodità per eventuali ispezioni nell'area comandi.

Extractable pedal controls for easy inspection of control area.

Ausziehbare Pedaleinheit, überaus praktisch für eventuelle Inspektionen im Steuerbereich.

ACCESSORI IN DOTAZIONE - STANDARD ACCESSORIES - STANDARDZUBEHÖR



DATI TECNICI - TECHNICAL DATA - TECHNISCHE DATEN

Autocentrante	Turntable	Spannfutter	
Capacità di bloccaggio interno	Inside clamping capacity	Spannbereich von innen	13" ÷ 26"
Capacità di bloccaggio esterno	Outside clamping capacity	Spannbereich von außen	10" ÷ 24"
Diametro massimo pneumatico	Maximum tyre diameter	Maximale Reifendurchmesser	1100 mm
Larghezza massima pneumatico	Maximum tyre width	Maximale Reifenbreite	360 mm (14")
Coppia di rotazione	Rotation torque	Drehmoment	1200 Nm (400v 3ph)
Velocità di rotazione	Rotation speed	Drehgeschwindigkeit	8 rpm - 13 rpm (x 2V)
Stallonatore	Bead breaker	Abdrücker	
Apertura massima	Maximum opening	Maximale Öffnung	380 mm
Forza paletta	Shoe force	Abdrückkraft Schaufel	15.500 N
Alimentazione	Power supply	Stromversorgung	
Tutte le alimentazioni	All power supply	Alle Stromversorgung	
Pressione di esercizio	Operating pressure	Betriebsdruck	10 bar

DIMENSIONI - DIMENSIONS - ABMESSUNGEN

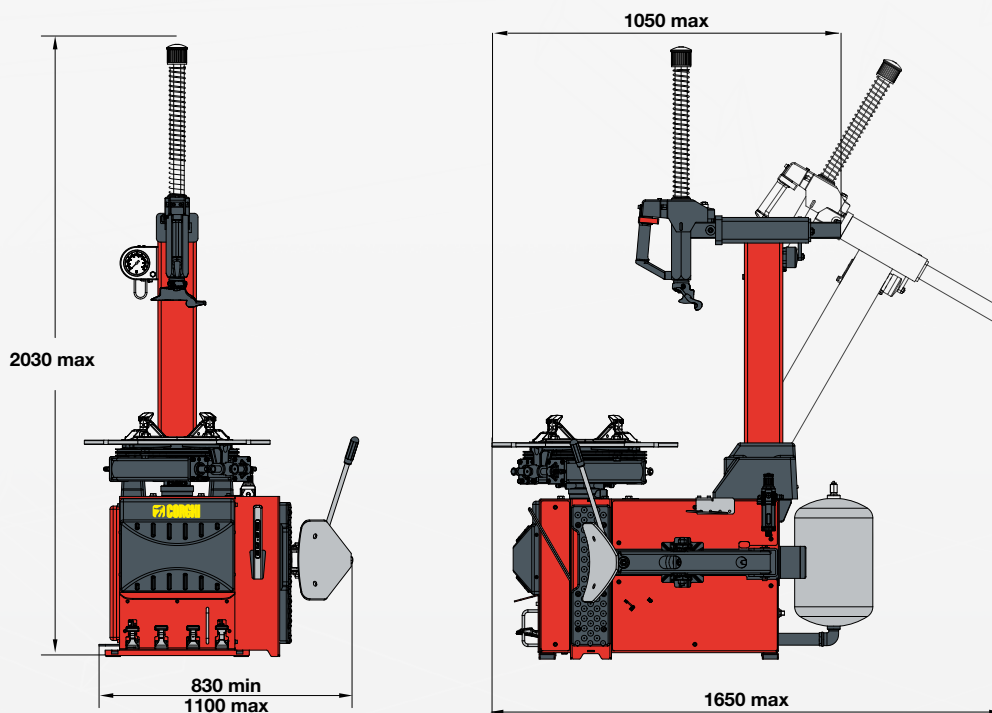

Peso della macchina / Machine weight / Maschinengewicht: 235 kg - TI 250 kg



NEXION SPA - ITALY - Società unipersonale soggetta a direzione e coordinamento di Minio srl - A sole shareholder Minio company

www.corgi.com - info@corgi.com



Fotografie, caratteristiche ed i dati tecnici non sono vincolanti, possono subire modifiche senza preavviso.
The manufacturer reserves the right to modify the features of its products at any time.
Fotografieren, Eigenschaften und technische Daten sind nicht bindend und können ohne Vorankündigung geändert werden.

Cod. DP0000046B - 05/2019

Per aiutare il pianeta ottimizzando il consumo di carta, i nostri cataloghi sono consultabili sul sito www.corgi.com. Una stampa responsabile aiuta a preservare l'ambiente, to protect the planet and reduce paper usage, our catalogues are viewable online at the website www.corgi.com. Printing responsibly contributes to saving the environment. Um unserm Planeten zu helfen und den Papierverbrauch zu optimieren, sind unsere Kataloge online auf der Webseite www.corgi.com einzusehen. Ein verantwortungsbewusster Ausdruck hilft, die Umwelt zu schützen.

