

 **CORGHI**

PL60



Manual
Gauge



Autobrake



CARATTERISTICHE PRINCIPALI - MAIN FEATURES

- **Equilibratrice compatta** per auto, veicoli leggeri e moto
 - Per stazioni di servizio e piccole officine
 - Doppio **display** digitale **ad alta luminosità**
 - Semplice da usare ed affidabile
 - Inserimento manuale delle dimensioni ruota
 - **Autodiagnosi** ed autocalibrazione
 - Completa di carter copiruota
 - Programmi di equilibratura in **modalità DYNAMIC, STATICA, 3 programmi ALU e MOTO**
 - Dotazione di centraggio da 4 coni (Ø 43 ÷ 156mm)
- **Compact wheel balancer** for cars, light truck vehicles and motorbikes
 - For service stations and small workshops
 - High brightness **double digital display**
 - Easy to use and reliable
 - Manual entry of wheel dimensions
 - **Self-diagnosis** and self-calibration
 - Complete with wheel cover casing
 - Balancing programs in **DYNAMIC, STATIC mode and 3 ALU and MOTO programs**
 - Centring equipment with 4 cones (Ø 43 ÷ 156mm)

DATI TECNICI - TECHNICAL DATA

alimentazione	power supply	230V/1ph/50Hz
potenza	power	250 W
velocità di rotazione	rotation speed	200 rpm
tempo medio di misura	Average measuring time	(con ruota da 20 kg - with 20 kg wheel) 7 sec
accuratezza	accuracy	±1g
rumorosità	noise	≤69dB
diametro cerchio	rim diameter	10" ~ 24"
peso massimo ruota	maximum wheel weight	65 kg
larghezza cerchio	rim width	1.5 ~ 20"
diametro massimo ruota	maximum wheel diameter	44 inch
dimensioni imballaggio	package dimensions	980*710*1160mm
peso netto	net weight	107 Kg
peso lordo	gross weight	137 Kg
quantità per container	quantity per container	34 sets (20 Ft)

DOTAZIONE - EQUIPMENT

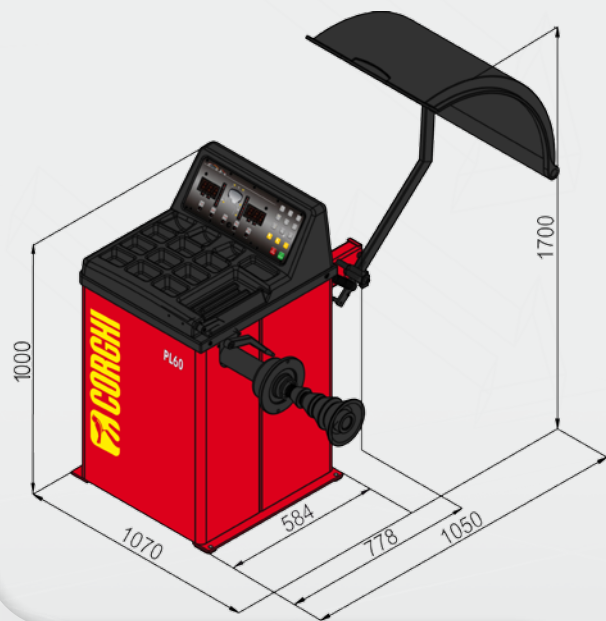

ACCESSORI CONSIGLIATI RECOMMENDED ACCESSORIES

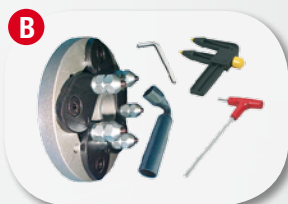

A 8-21100161
TT-80 - Sollevatore ruota.
TT-80 - Wheel lifter.

B 8-21100091
FRU Flangia autocentrante universale per ruote vettura senza foro centrale.
FRU Universal self-centring flange for wheels without central hole.

C 8-21100141
DX/CBF Accessorio di centraggio per furgoni e fuoristrada con foro centrale Ø 117÷173 mm.
DX/CBF Centring accessory for van and off-road wheels with central hole with Ø 117÷173 mm.



NEXION SPA - ITALY - Società unipersonale soggetta a direzione e coordinamento di Minio srl - A sole shareholder Minio company

www.corgi.com - info@corgi.com



Fotografie, caratteristiche ed i dati tecnici non sono vincolanti, possono subire modifiche senza preavviso.
The manufacturer reserves the right to modify the features of its products at any time.

Cod. **DFCG001044** 09/2019

Per aiutare il pianeta ottimizzando il consumo di carta, i nostri cataloghi sono consultabili sul sito www.corgi.com. Una stampa responsabile aiuta a preservare l'ambiente.
To protect the planet and reduce paper usage, our catalogues are viewable online at the website www.corgi.com.
Printing responsibly contributes to saving the environment.

